

# Fixed Chemical Injector

CPVC Body and Nozzle

## FEATURES

- Designed specifically for carwash applications
- Made in the USA
- A cost effective solution to your chemical application needs



## SPECIFICATIONS

MODEL	100955	100956	100957
Orifice	1.4 mm	1.6 mm	2.1 mm
Flow Rate	1.0 to 2.0 GPM	2.0 to 3.0 GPM	3.0 to 5.0 GPM
O-Ring Material	Viton		EPDM
Inlet	1/2" NPT-M		
Outlet	1/2" NPT-M		
Max. Temperature	190° F		
Hose Barb	1/4"		
Weight	.4 lbs.		
Materials	CPVC, Kynar, Teflon		

## DIMENSIONS

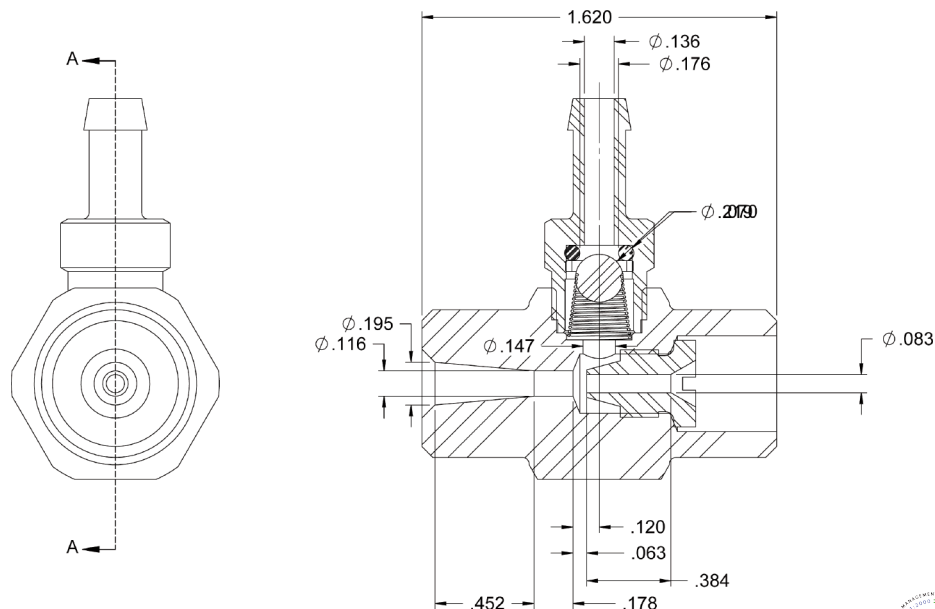

General Pump  
is a member of  
the Interpump Group

SECTION A-A  
SCALE 2 : 1



# Fixed Chemical Injectors

## CPVC Body and Nozzle

**GENERAL PUMP** *A member of the Interpump Group*

### INSTALLATION

This product is to be used with clean, fresh water. For different or corrosive liquids, contact GP Technical Service Department. With not clean liquids, appropriate filtration should be installed. Select the injector based on the nominal operating rating: system rated pressure, max flow and max temperature. Install valve with direction arrow pointing downstream. For proper operation a control device such as a dual lance wand, quick couple nozzles, or an adjustable nozzle holder must be used to lower the system pressure at the nozzle.

Under no circumstances should the pressure of the system exceed the maximum rated pressure of any component.

### TROUBLESHOOTING

PROBLEM	CAUSE	SOLUTION
Injector will not draw liquid	Incorrect nozzle System is not in low pressure mode  Discharge hose is too long  Chemical line is clogged	Check and change nozzle Change or adjust nozzle to put system in low pressure mode Reduce length of discharge hose or change injector* Clear chemical line of obstruction
Rate of draw seems too slow	Discharge hose is too long  Air leak in chemical line Chemical is too viscous	Reduce length of discharge hose or change injector* Locate and repair leak Reduce chemical with water to decrease its viscosity
Chemical injector is leaking from hose barb	Obstruction in hose barb checkvalve  Damaged o-ring in checkvalve	Disassemble and remove obstruction  Remove and replace o-ring
Excessive pressure load on pump, motor or engine	Clogged injector Improperly sized injector orifice	Clear injector orifice of obstruction Change orifice*

\*Contact GP Technical Service for Assistance

### PARTS LIST

Item	Part Number	Description	QTY.
1	660128	Housing, Injector, CPVC	1
2	720038	Spring, Conical Hastalloy	1
3	660114	Ball, Injector, 7/32" Dia.	1
4	701032	O-ring, 50 DURO,Viton	1
	701059	O-ring, 50 DURO, EPDM (100957)	1
5	660110	Retaining Ring, Kynar	1
6	660126	Hose Barb, Kynar	1
7	660178	Nozzle, Injector, CPVC (100955)	1
	660179	Nozzle, Injector, CPVC (100956)	1
	660149	Nozzle, Injector, CPVC (100957)	1

